

---

INSTITUTE OF COSMOS SCIENCES  
UNIVERSITY OF BARCELONA

# 2020 ANNUAL REPORT

$\vdash Z(1, 1, 2)$

---

Institute of Cosmos Sciences of the University of Barcelona.

Published in Barcelona, November 1st 2021.

This report has been written and designed by the Scientific Office.

# CONTENTS

---

<b>FOREWORD</b>	<b>4</b>
<b>GOVERNING BODIES</b>	<b>6</b>
<b>ICCUB IN FIGURES</b>	<b>7</b>
<b>RESEARCH HIGHLIGHTS</b>	<b>10</b>
• Cosmology and Large Scale Structure	11
• Experimental Particle Physics	13
• Galaxy Structure and Evolution	14
• Gravitation and Cosmology	16
• Hadronic, nuclear and atomic physics	17
• High Energy Astrophysics	19
• Particle Physics Phenomenology	21
• Quantum Field Theory and String Theory	23
• Quantum Technologies	24
• Star Formation	25
<b>LIFE AT THE ICCUB</b>	<b>27</b>
<b>TECHNOLOGICAL UNIT</b>	<b>31</b>
<b>OUTREACH</b>	<b>35</b>

# FOREWORD

---

2020 has been an eventful year, for the ICCUB and for all of us. The COVID-19 pandemic has marked and conditioned our work for most of the year, changing drastically our work conditions and preventing the fluid and frequent meetings that characterize scientific work. But we have persevered, and we have adapted to the new situation. We have learned to better use our communication tools and teleworking has become a standard. We have been forced to move meetings, seminars, workshops and colloquia to the virtual world and to work in more isolated conditions. All in all, COVID-19 may have somewhat slowed us, but has not stopped us.



2020 has also brought good news to the ICCUB. We have again been awarded Maria de Maetzu Excellence award, our second one. We can count again with increased financial support for the institute activities in the next four years to implement our strategic plans. We will be able to hire strategic postdoctoral researchers, to provide enhanced administrative support and to further boost our technological unit. And as further good news, Dr. Hector Gil-Marin was awarded the young researcher



Héctor Gil Marín

prize on theoretical physics by the Real Sociedad Española de Física-Fundación BBVA and Dr. José Luis Bernal received the award to the best PhD thesis by the Spanish Astronomical Society. Congratulations to both!



José Luis Bernal

In this year we have also further strengthened our participation in the Institut d'Estudis Espacials de Catalunya (IEEC). We have started new joint projects and have better integrated our resources. Of special interest is our participation through the IEEC in the Catalan NewSpace initiative to launch and operate nanosatellites. We look forward to further contribute to this project.

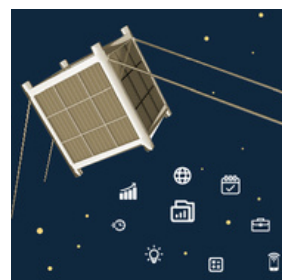

To close this foreword, we want to welcome our new members, Oleg Bulashenko, Atilà Herms, Maria Moreno and Arnau Rios. We also want to include here a sad farewell to Professor Artur Polls, who left us this year; we will miss you.

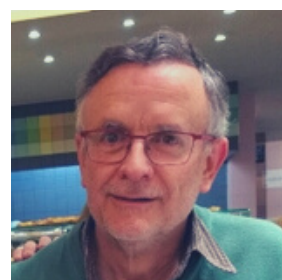

Professor Artur Polls

## Xavier Luri

## Assumpta Parreño

EXECUTIVE BOARD OF THE ICCUB



# GOVERNING BODIES

---

## executive board

Director: **Xavier Luri**

Deputy Director: **Assumpta Parreño**

Secretary: **Federico Mescia**

## council

V. Bosch

E. Graugés

F. Mescia

J.M. Paredes

F. Figueras

B. Julià

J. Miralda

A. Parreño

P. Garcia

X. Luri

I. Morera

À. Ramos

L. Garrido

D. Mateos

E. Pallares

A. Rios

## scientific board

R. Empanan

F. Mescia

V. Bosch

J. Garriga

X. Luri

J. Miralda

J. Casalderrey

B. Julià

D. Gascón

A. Parreño

M. Guilleumas

## colloquia comission

## international advisory committee

**Felix Aharonian**, Max Planck Institute für Kernphysik, Heidelberg. Chair

**Alan Heavens**, Imperial College, London

**Tatsuya Nakada**, École Polytechnique Fédérale de Lausanne, Lausanne

**Meghan Urry**, Yale Center for Astronomy and Astrophysics, EE.UU.

# ICCUB IN FIGURES

## STAFF

### Number of ICCUB members

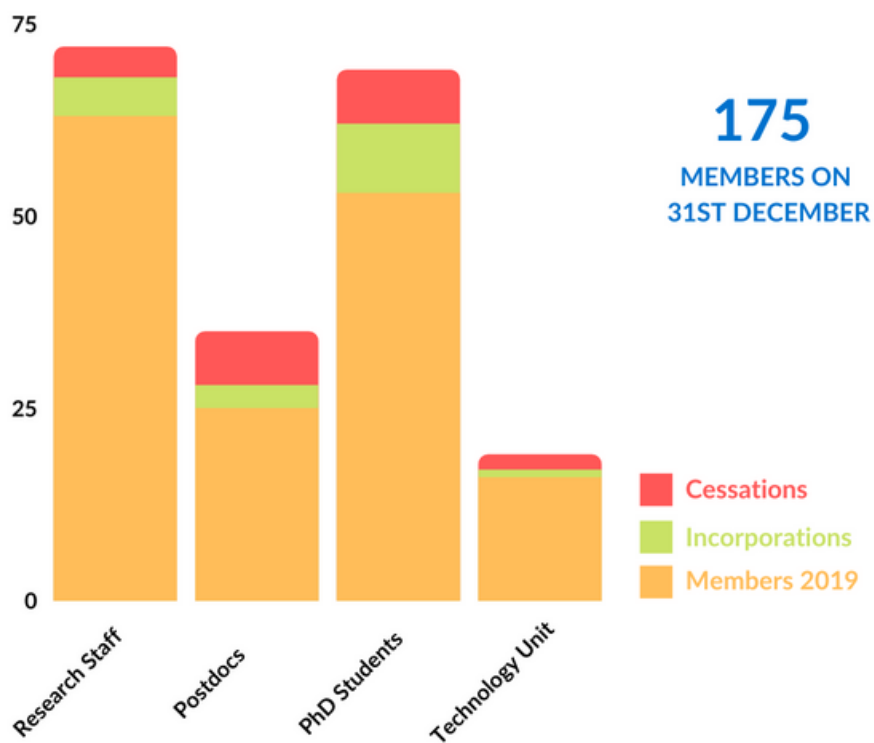

# GENDER

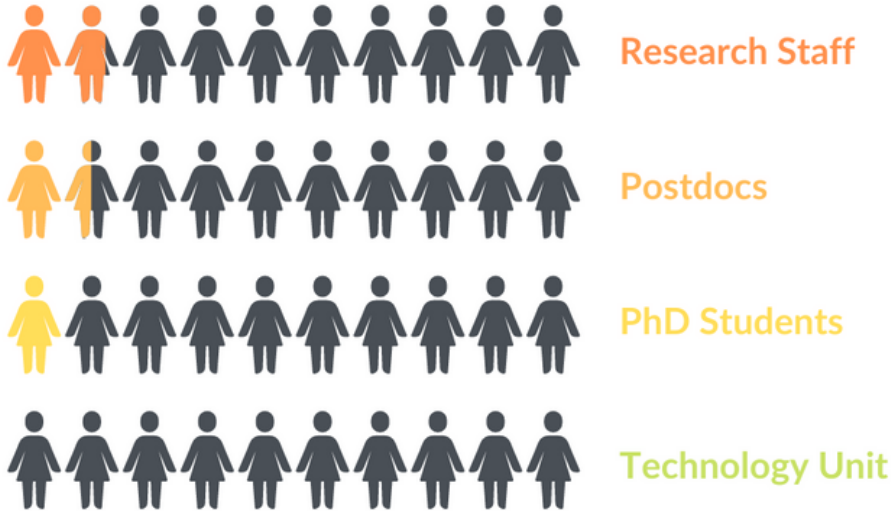

# EVOLUTION STAFF

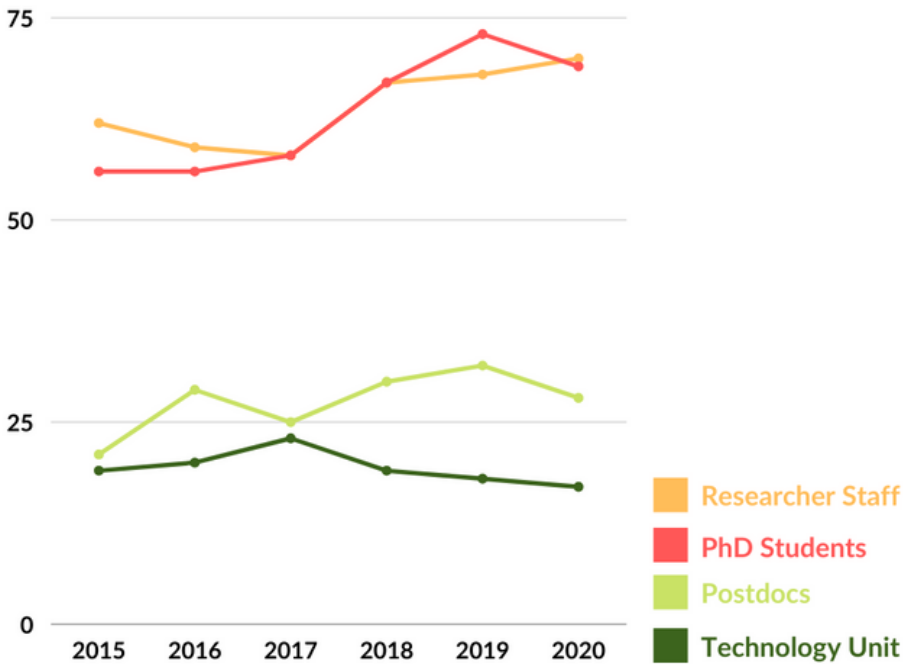



# ACTIVITIES

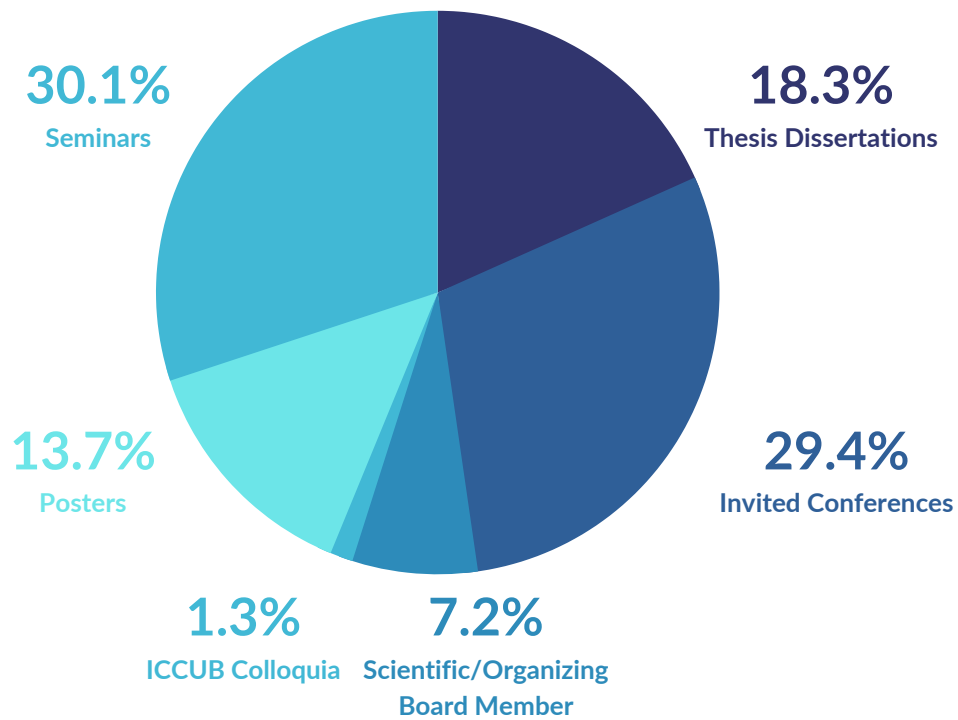

# FUNDING SOURCES

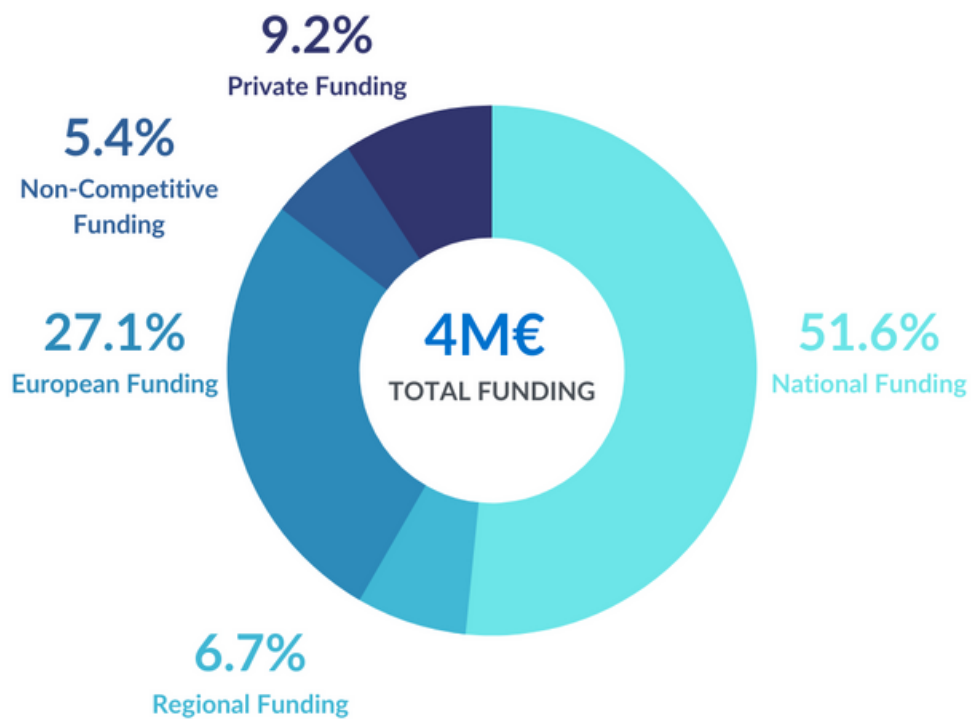

# RESEARCH HIGHLIGHTS

---

## PUBLICATIONS

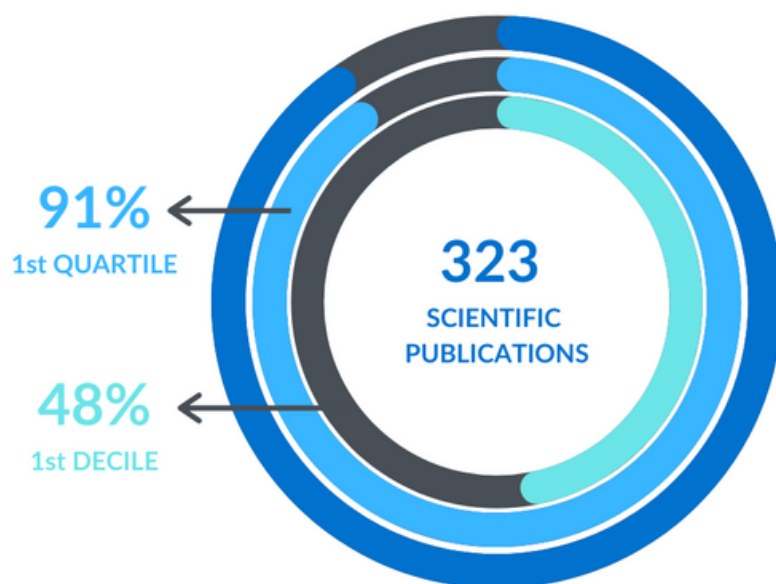

# COSMOLOGY AND LARGE SCALE STRUCTURE

The main focus on the research group has been on developing and fine tuning techniques to analyze state-of-the art and forthcoming cosmological data and galaxy surveys.

Significant work went into the final data release and papers from the e-BOSS survey [1] and ramping up our effort in preparation for the beginning of the DESI survey (May 2021). This include new approaches such as blinding [2] for spectroscopic surveys and higher order correlations (especially the trispectrum) including the anisotropic redshift space signal of the bispectrum.

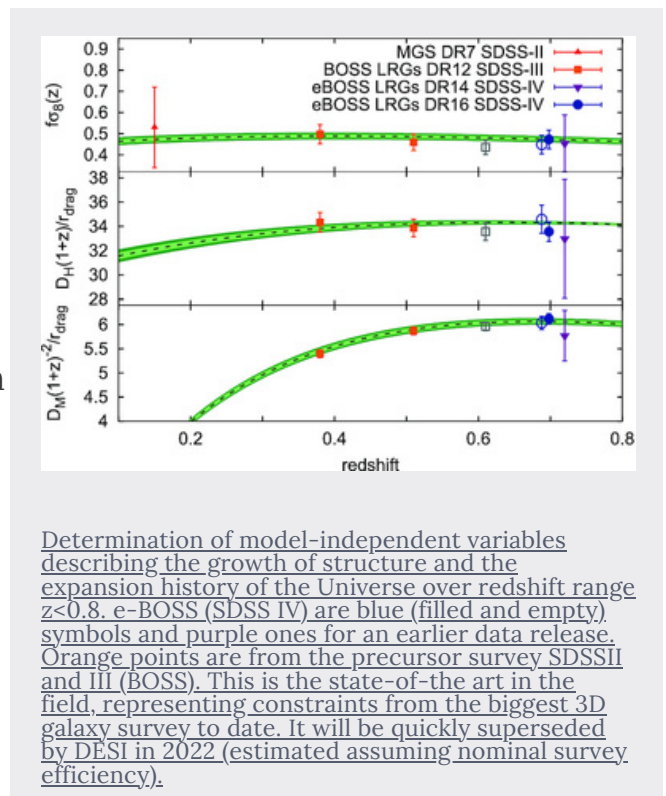

The possible detection of Lyman-alpha emitters (LAEs) at high redshift ( $z \sim 9$ ) would constrain the ionization history of the IGM. A deep image has been taken with a narrow band filter designed on purpose for the CIRCE nIR camera at GTC. The data analyst is do not allow to constrain the luminosity function of LAEs at  $z \sim 9$ , but the work suggests that a fainter limiting magnitude can be obtained in other nIR cameras.

The impact of cold dark matter subhalos on observations of magnified galaxies in lensing clusters [3] and that of axion dark matter minihalos on observations of highly magnified stars crossing lensing caustics [4], was analyzed.

Finally, we have also presented a new determination of the age of the Universe from a Bayesian analysis of a large sample of globular clusters observations [5]. This determination can weigh in on the  $H_0$  controversy.

# COSMOLOGY AND LARGE SCALE STRUCTURE

---

## Main scientific results:

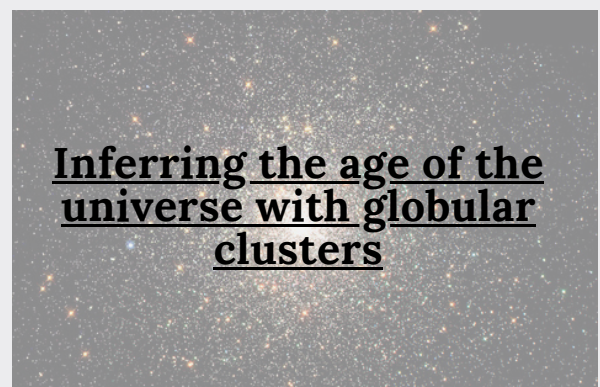
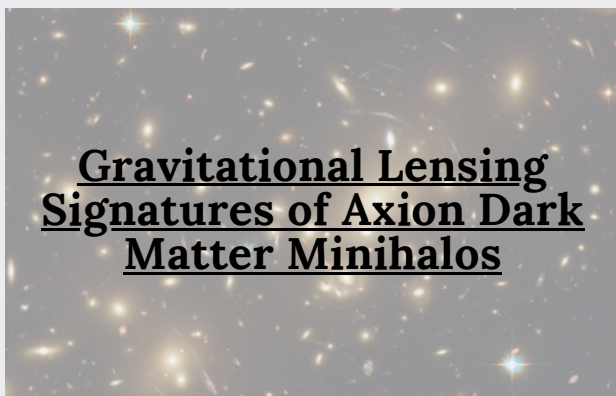
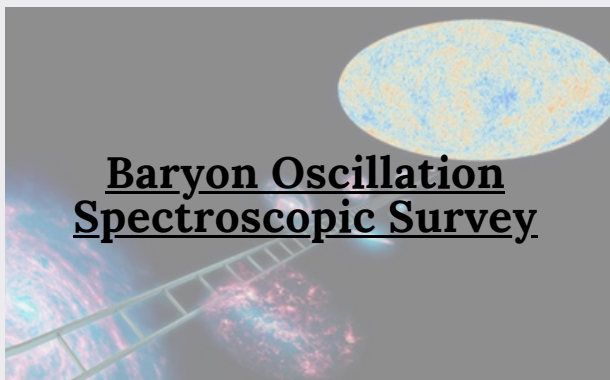

# EXPERIMENTAL PARTICLE PHYSICS

The ICCUB participation in the LHCb experiment has resulted in important scientific results in 2020. Those with highest impact are related to new decay observations, with new discovered states and in the search of new physics beyond the Standard Model (SM) of particles and fields in rare b-quark decays. Namely,

a) Observation of structure in the  $J/\psi$ -pair mass spectrum, at regions covering predicted masses of states composed of four charm quarks. The mass and natural width of the narrow X(6900) structure are measured. Read the article [here](#).

b) Measurement of CP-Averaged Observables in the  $B^0 \rightarrow K^*0\mu^+\mu^-$  Decay, angular analysis where the tension seen between the previous LHCb results and the standard model predictions persists with the new data. Read the article [here](#).

c) Angular Analysis of the  $B^+ \rightarrow K^{*+}\mu^+\mu^-$  Decay, where, for the first time, the full set of CP-averaged angular observables is measured in intervals of the dimuon invariant mass squared. Local deviations from standard model predictions are observed, similar to those in previous LHCb analyses of the isospin-partner  $B^0 \rightarrow K^*0\mu^+\mu^-$  decay. Read the article [here](#).

a) Observation of structure in the  $J/\psi$ -pair mass spectrum

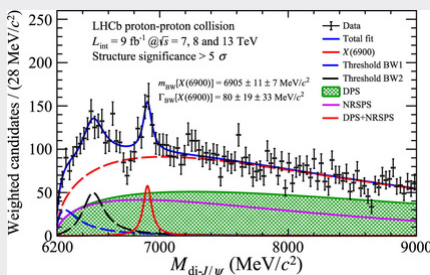

b) Measurement of CP-Averaged Observables in the  $B^0 \rightarrow K^*0\mu^+\mu^-$  Decay

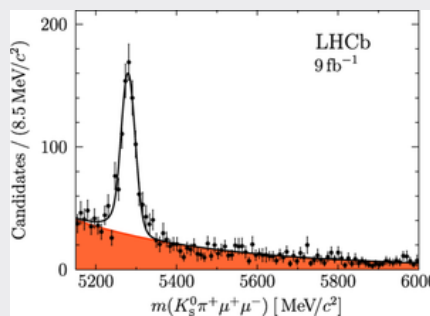

c) Angular Analysis of the  $B^+ \rightarrow K^{*+}\mu^+\mu^-$  Decay

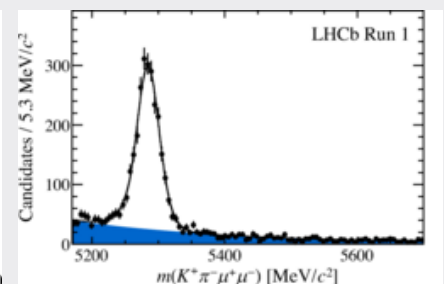

# GALAXY STRUCTURE AND EVOLUTION

The Gaia mission is revolutionizing astrophysics and 2020 has been another key year with the delivery of the Early third Data Release (EDR3) with 1.8 billion sources, an improvement of 20% in the precision of parallaxes, a factor 2 in proper motions and improved photometry replacing the previous release. The ICCUB has a first-line participation in this achievement through a leading role in Data Processing and Analysis Consortium. The ICCUB has participated in three (leading two) out of four articles to illustrate the impact and potentiality of EDR3: the studies of the Galactic anticentre that reveals the complexity of the structure of the Galaxy and its formation history, and of the kinematics of stellar populations of the Magellanic Clouds for the first time for an external galaxy (see Figure XX). Additionally, the scientific exploitation of the Gaia data has continued, including the discovery of multiple new open clusters and their characterization, and the first study of the full Sagittarius stream including the determination of its proper motion along its full path. The involvement in WEAVE survey for spectroscopic complementary data has continued. Work on the search for tidal tails in the Milky Way halo has continued, developing a numerical code to evaluate a likelihood function to determine when a tidal tail is present and find the most likely member stars.

## Main scientific results:

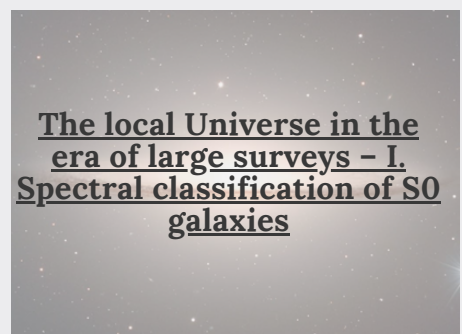
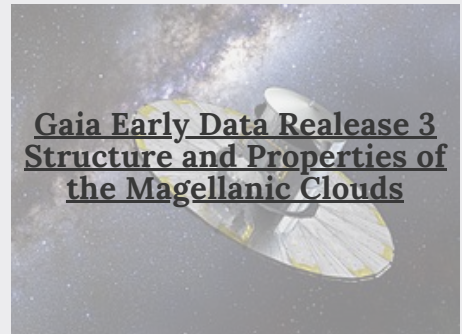

# GALAXY STRUCTURE AND EVOLUTION

It has been applied to the globular clusters M68 and NGC 3201 over a large section of the sky. The tails are being used to constrain the shape of the Milky Way dark matter halo. Using state-of-the-art instrumentation in the largest optical telescopes, we have discovered and characterized ultra diffuse galaxies (with the aim to reveal their still unknown origin) and the stellar properties of the extremely diffuse shells around massive galaxies and the outermost parts of massive galaxy halos. One of our main focuses is on the more compact objects at the low-mass end. They are so small that resolving their data to obtain spatial information is a big challenge, but our group has obtained and analyzed IFU data and is now working on the largest sample available on the search for black holes in their centers, the ultimate key to understand their origin (see Figure XX).

A PCA analysis of the spectra of a bias-free machine-learning-based classification of the lenticular galaxies in the Local Universe ( $z < 0.1$ ) has revealed two main sub-populations. Compared to the absorption-dominated S0, the second group (at least a quarter of the local S0 population) shows star formation rates and spectral characteristics entirely similar to those seen in late spirals, and avoid high-galaxy density regions. These findings suggest that actively star-forming S0 galaxies might be much less rare than hitherto believed.

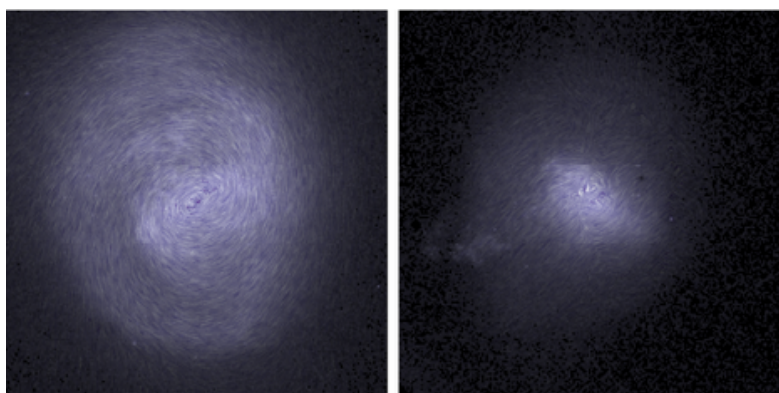
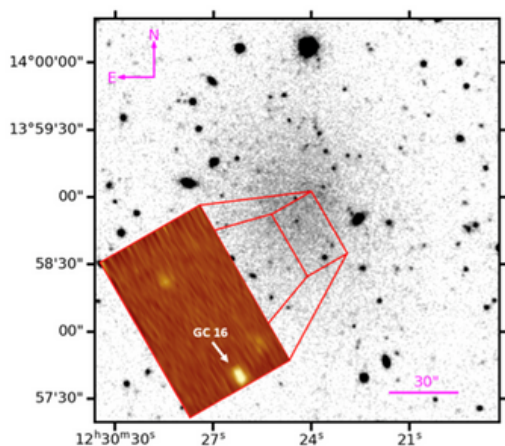

Illustration of the proper motion field of the LMC (left) and SMC (right) using line-integral convolution. We set the alpha parameter (opacity) of the coloured lines according to the density, with the densest regions being the most opaque.

# GRAVITATION AND COSMOLOGY

## Classical and quantum physics of black holes and cosmic censorship.

A major review by Emparan and Herzog (from KCL) was published on the large-D limit of gravity. Emparan and Tomašević, with UCSB researchers, proved that multi-wormholes are possible. Emparan, Frassino and Way employed holography to exactly solve for a quantum black hole, and Emparan and Tomašević argued that strong cosmic censorship is always upheld with quantum effects. A team of ICCUB researchers (Andrade et al) studied the fusion and fission of black holes and the production of entropy. Andrade and collaborators in the UK showed the spectacular evolution of a black hole collision with a novel violation of cosmic censorship. Emparan and Marin discovered the ‘precursory collapse’ in a neutron star/black hole merger.

Escrivà, Germani and Seth extended their studies of primordial black hole formation to cosmologies and obtained the required compaction.

## Theoretical cosmology.

Notari et al investigated whether the tension in the values of  $H_0$  can be alleviated with a varying Newton’s constant: The improvement is marginal, similar to other models. In a different collaboration, Notari studied the production of light axions across an electroweak phase transition, finding observable effects in future surveys of the CMB.

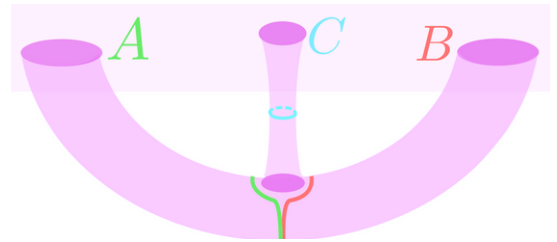

Fig. 1. Multi-mouth traversable wormhole

## Main scientific results:

### Large D limit of Einstein’s equations

### The $H_0$ tension: $\Delta$ GN vs. $\Delta$ $N_{eff}$

### Quantum BTZ black hole

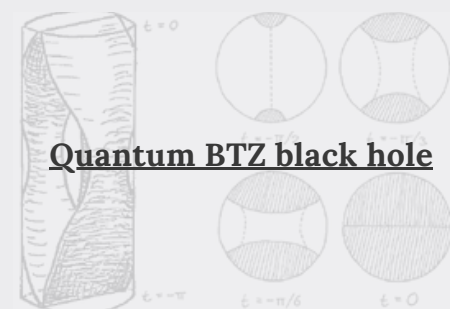



# HADRONIC, NUCLEAR AND ATOMIC PHYSICS

## Machine learning the deuteron

Machine learning has experienced a rapid evolution over the last decade, providing new algorithms and methods that can now tackle problems with a high degree of complexity, such as that encountered in quantum many-body systems, the atomic nucleus being a paradigmatic example. We have used off-the-shelf machine learning techniques to simulate

the simplest nuclear bound state - the deuteron. We set up a variational problem to solve the Schrödinger equation, find the wave-function and compute the ground-state energy. These proof-of-principle results fall within 0.1% of exact diagonalization benchmarks and pave the way for future machine-learning-based simulations of nuclear (and other quantum) few- and many-body systems.

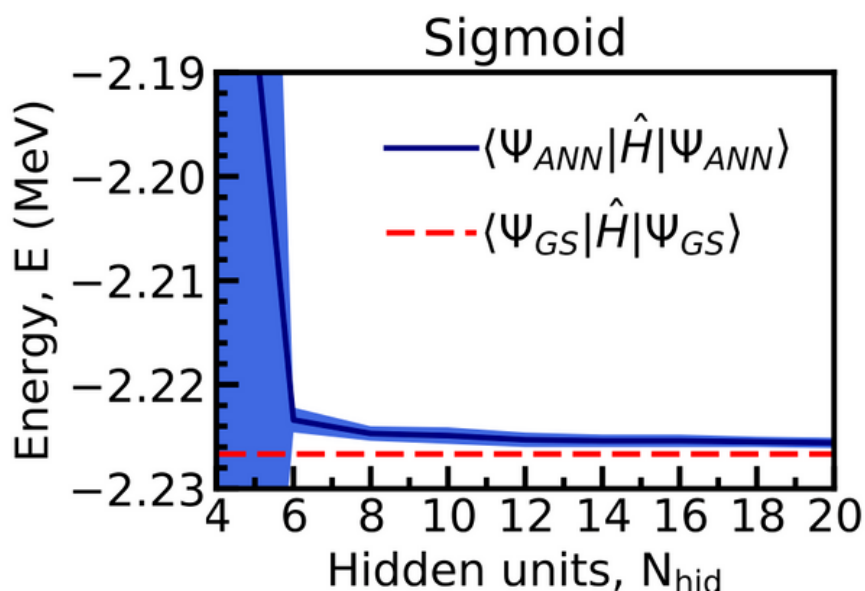

**Figure 1.** Binding energy of the deuteron as a function of the number of hidden layer nodes,  $N_{hid}$ . Lines (bands) are obtained from the average (standard deviation) of 50 independent VANN runs. Horizontal (dashed) lines show the benchmark result.

# HADRONIC, NUCLEAR AND ATOMIC PHYSICS

## The GW170817 constraints analyzed with finite-range nuclear interactions

Neutron star observations and in particular the gravitational wave data from LIGO/Virgo represent an exceptional opportunity to better understand the properties of strongly interacting matter at large values of density and isospin asymmetry. Due to the difficulties to access matter under these extreme conditions in the laboratory, it is important to analyze the impact of the recent data within different types of nuclear models.

We have employed a set of finite-range nuclear interactions to investigate the constraints on the equation of state from the LIGO/Virgo observation of GW170817, an event accounting for the merger of two neutron stars. We have studied the neutron star tidal deformabilities, the mass-radius diagram, the maximum mass, and the moment of inertia to formulate connections between the tidal deformability and the other quantities. In the analysis of the moment of inertia of a neutron star as a function of the tidal deformability, we have shown that the so-called I-Love relation, which is expected to be universal, is also satisfied by the considered interactions. We also have found strong correlations among the tidal deformability of a canonical neutron star, its radius, and the derivatives of the nuclear symmetry energy at the saturation density.

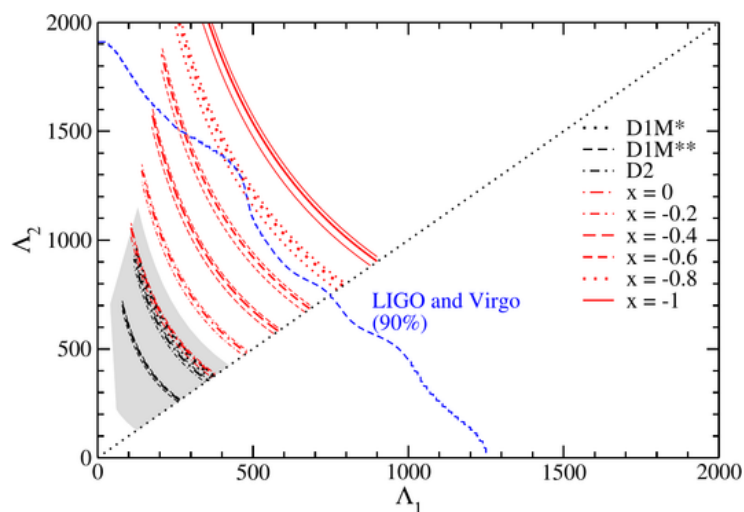

**Figure 2.** Dimensionless tidal parameters  $\Lambda_1$  and  $\Lambda_2$  related to the high and low mass components inferred from the binary system of the GW170817 event, along with the contour line of 90% credible level (dashed blue curve).

# HIGH ENERGY ASTROPHYSICS

**MAGIC Collaboration.** We have conducted observational shifts, continued the monitoring of galactic X-ray binaries, hosted the meeting of the MAGIC AGN working group and reported results in Collaboration meetings (New hard-TeV extreme blazars detected with the MAGIC telescopes, An intermittent extreme BL Lac: multi-wavelength study of 1ES2344+514 in an enhanced state). One of the members of the group has been convener of the physics working group on extragalactic sources, and another one has been deputy physics coordinator, whereas two members have been part of the Time Allocation Committee. Within the CTA Consortium, we have taken observational shifts to the LST1, and participated in many teleconferences to discuss physics prospects with CTA. In close collaboration with members of the Technological Unit, we have also continued our developments in electronics for CTA, and have won a bit for a tender to build the cameras of LST2-LST4.

**Theoretical Astrophysics.** we have proposed for the first time that primordial black holes (PBH) should accrete significantly less than expected if they have winds or jets, even if they are weak (Mechanical feedback effects on primordial black hole accretion). We have also proposed that the jet lobes of AGNs could have contributed significantly ( $\sim 10\%$ ) to the reionization of the Universe to redshift  $\sim 6$  (AGN jets versus accretion as reionization sources). We have also published a review paper on blazar modeling (Leptonic and Hadronic Radiative Processes in Supermassive-Black-Hole Jets). Finally, we have published the most complete model up to date of the gamma-ray binary LS 5039 (A dynamical and radiation semi-analytical model of pulsar-star colliding winds along the orbit: Application to LS 5039).

## Main scientific results:

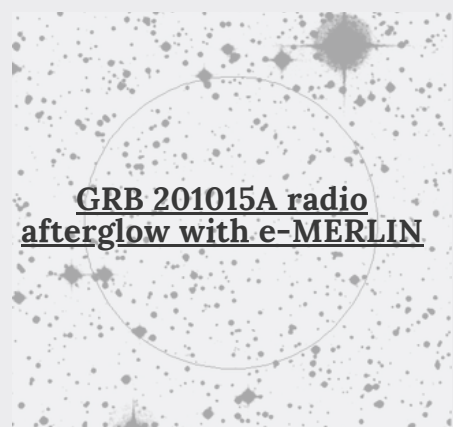
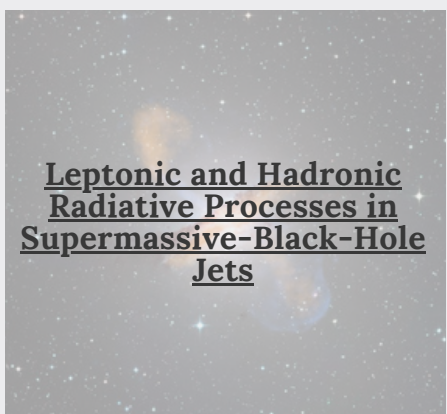

# HIGH ENERGY ASTROPHYSICS

## Radio, optical, X-ray & Gamma-ray observations.

We have conducted VLBI observations of a GRB afterglow. In 2020GCN28939 and 2020GCN29028 we show the GRB 201015A radio afterglow detected with e-MERLIN and EVN, respectively. We have published papers on X-ray deep survey fields and dual AGN in galaxy mergers, using the X-ray observatories Chandra, XMM-Newton and NuSTAR and the optical facilities of Subaru, ESO and Keck. These publications have resulted in two press releases on large-scale structure at high redshift and dual quasars. We have discovered and characterized the jet-like features in the runaway pulsar PSR J1135-6055 (Jet-like structures from PSR J1135-6055), and reviewed the discovery of the periodic gamma-ray emission from SS 433 with the Fermi-LAT telescope (Gamma-ray echoes from SS 433).

At VHE gamma-rays, we reported on the discovery of a new galactic PeVatron candidate (An extreme particle accelerator in the Galactic plane: HESS J1826-130). We have also reported the observations of the 2014 and 2017 periastron passage of the gamma-ray binary PSR B1259-63 with the Fermi-LAT and H.E.S.S. Telescopes (H.E.S.S. and Fermi-LAT observations of PSR B1259-63/LS 2883 during its 2014 and 2017 periastron passages).

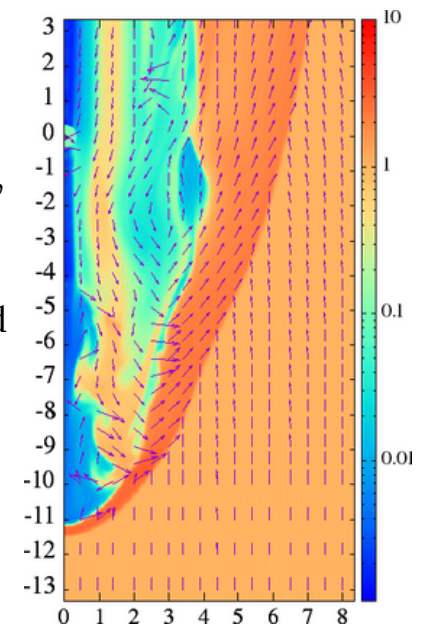

Density maps of the outflow-medium interaction structure in a PBH

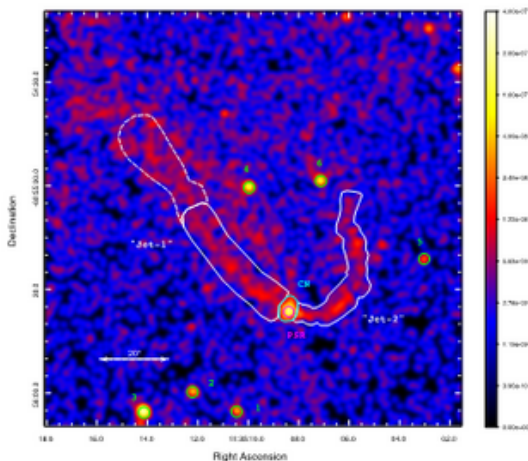

Extended emission around PSR J1135-6055 for energies in the range 0.5-7.0 keV



Artist's impression of the web around a supermassive black hole

# PARTICLE PHYSICS PHENOMENOLOGY

The activity was influenced to a large extent by recent LHC results. Studies in this area focused on effective theories, flavor physics (particularly B-physics) and physics beyond the Standard Model that the LHC will continue exploring in the years to come.

In the area of B-physics, ICCUB researchers have been worked to clarify the recent anomalies come out from the new results of LHCb and Belle. Our work focus on three areas: (1) Improvement of theoretical predictions through the refinement of QCD effects, (2) global fits, and (3) BSM interpretations within the Standard Model Effective Field Theory (SMEFT) (for generic New Physics above the TeV), and within specific models of New Physics. Moreover, we developed a wide "SMEFT-Tools" programs for developing software that automatically performs matching and running calculations within the SMEFT is important. This is the object of the public code DsixTools, which we have developed during the last three years and which has to be consistently maintained and improved over the next few years in order to expand its scope and improve its performance. The confirmation of new interactions or/and new particle from these anomalies can be address also a candidate of DM. In this line, we have studied a class of models with DARK matter candidates and compatible with the B-physics anomalies.

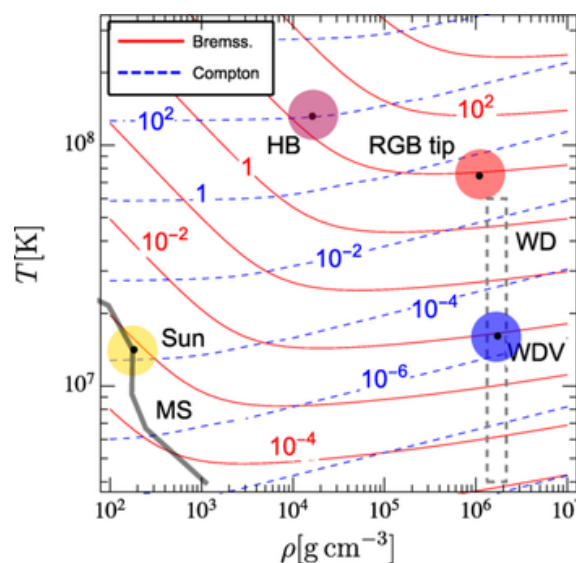

Contours of the axion energy-loss rates per unit mass, in  $\text{erg g}^{-1}\text{s}^{-1}$ , for a pure He plasma and  $g_{e13}=4.3$ .

# PARTICLE PHYSICS PHENOMENOLOGY

---

Apart from this, effective theories of QCD, especially in the heavy quark sector and in high temperature, were intensively studied. Several features of heavy ion collisions or also received considerable attention.

Finally, very relevant contributions were made in the field of neutrino. First, we perform a global fit to neutrino oscillation and coherent neutrino-nucleus scattering data. we quantify for the first time the less precisely known parameters  $\theta_{23}$ ,  $\delta_{CP}$ , and the neutrino mass. Moreover, we have shown that the current cosmological neutrino mass bound is fully avoided in the presence of a long range interaction, opening the possibility for a laboratory neutrino mass detection in the near future.

About axion research, the ICCUB members have realized a new and important theoretical study to constraint the coupling of axion with two photons in view of new experiments.

# QUANTUM FIELD THEORY AND STRING THEORY

We have used holography to address several problems in Quantum Field Theory. We have proposed a new holographic realization of Complex Conformal Field Theories, which play an important role in the generation of mass hierarchies; **we have performed the first simulation of the real-time evolution of droplets of deconfined plasma**; and we have investigated the dynamics of phase separation in theories with a first-order phase transition.

In the context of Heavy Ion Collisions, we have analysed the role that the quark-gluon plasma resolution length plays in understanding the modification of jet substructure due to interactions with the plasma.

We have employed supersymmetric localization to obtain the perturbative expansion of several observables on the four-sphere of four dimensional Lagrangian  $N = 2$  superconformal field theories, to all orders in the 't Hooft coupling, in the planar limit.

We have examined the large-charge limit of theories in different numbers of dimensions. We have shown that many interesting properties can be computed exactly in this limit. We have also discovered interesting phase transitions in matrix models.

We have uncovered new symmetry structures in non-relativistic limits of quantum field theories and string theories.

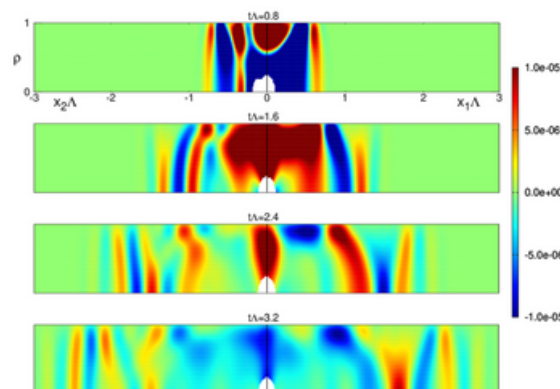

**Figure 1.** A plasma ball is a droplet of deconfined plasma surrounded by a confining vacuum in a confining gauge theory with mass gap  $\Lambda$ . Holography maps its dynamics to that of a localized, finite-energy black hole in five-dimensions coupled to a scalar field. We have performed the first simulation of its real-time dynamics. The figure shows several snapshots of the scalar field. The horizontal axis corresponds to the gauge theory directions. The vertical axis is the holographic fifth dimension. The black hole is the white region at the bottom-center of the figure. As seen in the figure, its relaxation to equilibrium emits gravitational and scalar radiation which is interpreted as the emission of particles in the gauge theory. We have discovered that the equilibration process takes longer than naively expected. This feature is a direct consequence of confinement and is caused by long-lived, periodic disturbances bouncing between the bottom of the AdS soliton and the AdS boundary, as can be seen in the figure.

# QUANTUM TECHNOLOGIES

## Novel lattice quantum liquids

We have recently proposed an extension of Petrov's quantum droplets to one-dimensional optical lattices. Lattice quantum droplets present two relevant features that make them extremely interesting for both experimental and theoretical investigation. First, they appear also in the strongly interacting regime, unlike Petrov's, where they give rise to a dimerised quantum liquid which features universal properties, i.e. the many-body physics can be inferred to a large extent by the properties of the effective dimer-dimer interaction.

## Quantum Simulation of Gauge Theories

We excite the vacuum of a relativistic theory of bosons coupled to a  $U(1)$  gauge field in 1+1 dimensions (bosonic Schwinger model) out of equilibrium by creating a spatially separated particle-antiparticle pair connected by a string of electric field. During the evolution, we observe a strong confinement of bosons witnessed by the bending of their light cone, reminiscent of what has been observed for the Ising model.

## Probing Thermalization through Spectral Analysis with Matrix Product Operators

We combine matrix product operator techniques with Chebyshev polynomial expansions and present a method that is able to explore spectral properties of quantum many-body Hamiltonians. In particular, we show how this method can be used to probe thermalization of large spin chains without explicitly simulating their time evolution, as well as to compute full and local densities of states.

## Main scientific results:

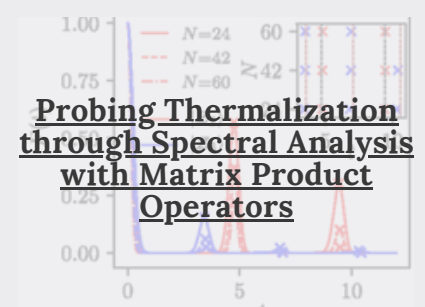
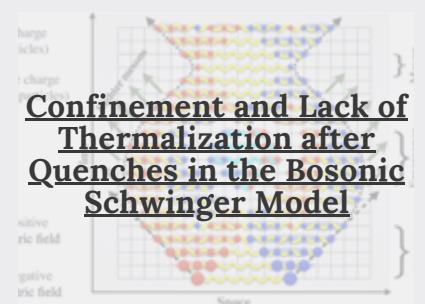
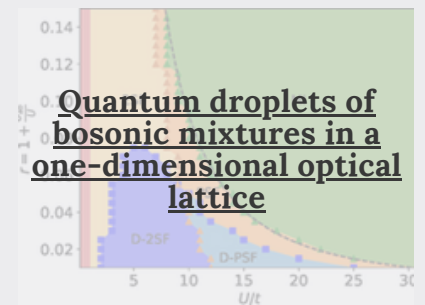



# STAR FORMATION

We have carried out observational studies of both low-mass and high-mass star-forming regions, to study their fragmentation properties and their dynamics. In the molecular cloud L1287, we have performed optical H-alpha and [SII], and VLA NH<sub>3</sub> (1, 1) and (2, 2) observations with an angular resolution of 3.5 arcsec, revealing a dense core and dense filaments with clear signatures of gas infall onto a central object of approximately 2.1 solar masses. In our study of the GGD 27-MM1 high-mass protostar, with high angular resolution (40 mas) ALMA observations at 1.14 mm, we have revealed a compact ( $R = 200$  au), flattened dust structure perpendicular to the HH 80-81 jet, making it a robust candidate for a true accretion disk (Fig. 1). We have estimated a disk mass of 5 solar masses, and a stellar mass of 20 solar masses, and have improved the distance estimate based on Gaia DR2 data.

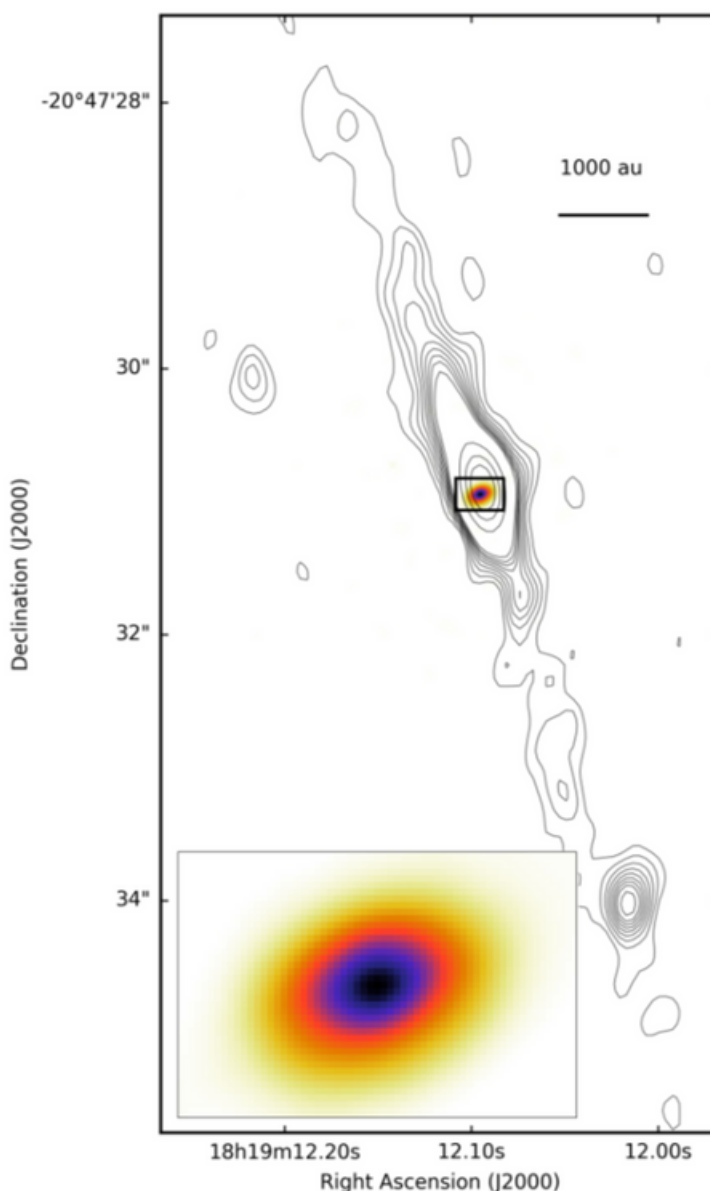

**Fig. 1:** Disk and jet system of the massive star GGD 27-MM1. The color image shows the dust continuum emission of the disk observed with ALMA at 1.14 mm with 40 mas angular resolution (~56 au). In contours, the VLA image at 3.6 cm of the radio jet observed with an angular resolution of ~0.4 arcsec (Carrasco-González et al. 2012).

# STAR FORMATION

The theoretical work has been focused on the study of the role of supernova (SN) feedback in the formation and dispersal of molecular clouds (MCs) and on the development of a new model for the origin of massive stars. By analyzing our state-of-the-art star-formation simulation at a scale of 250 pc, we have shown that the lifetime of MCs can be explained as the consequence of SN explosions, with SNe born inside the MCs playing the main role. We have also demonstrated that the formation of massive stars is not as fast as previously assumed, as it requires inflowing gas from large scale (Fig. 2), and have challenged basic assumptions of current models for the origin of the mass distribution of stars.

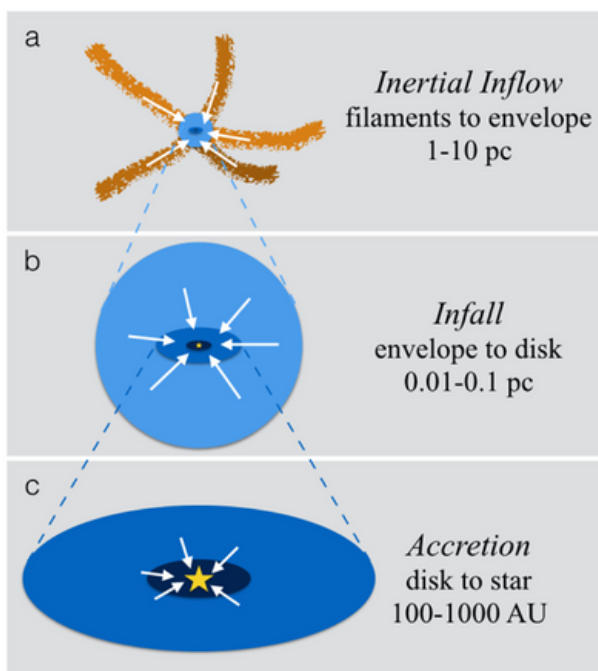

**Fig. 2:** Sketch of the different scales in the new Inertial-Inflow model of massive star formation.

## Main scientific results:

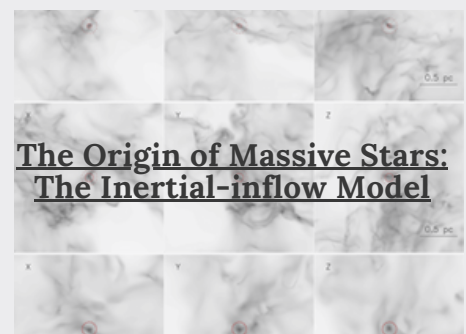
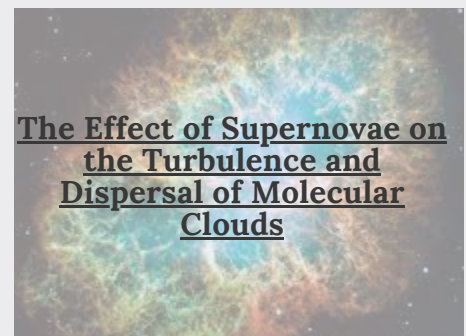
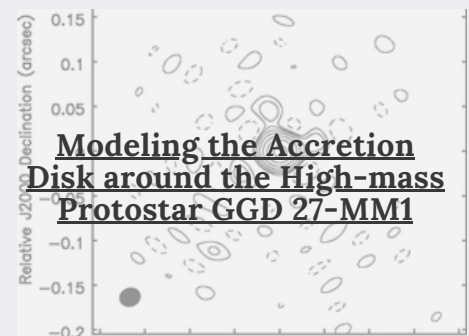
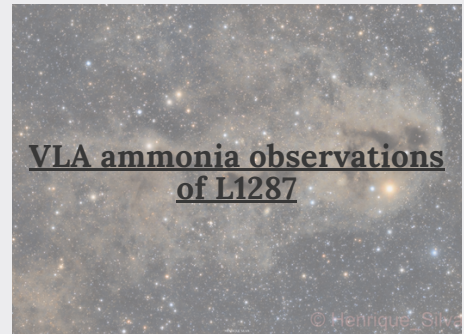

# LIFE AT THE ICCUB

---

## The ICCUB contributes to the production of medical equipment with 3D printers

The Technological Unit of the Institute of Cosmos Sciences is one of the research groups that has joined the initiative of the Fab-LabUB of the University of Barcelona, where researchers from the Faculties of Physics, Chemistry, Medicine and Fine Arts also participate.

The Fab-Lab UB group was organized during the month of March, when the authorities and the professionals of the sanitary facilities warned of the need to increase the stock of protective material for health technicians and professionals. The University of Barcelona, searched for those departments and research groups that had 3D printers, and organized working groups to produce and distribute material among the health centres that requested it. So far, the Fab-Lab UB has manufactured more than 695 protective screens, 98 door openers and 1270 ear protection units.



# WELCOME

---

## Oleg Bulashenko



I decided to join the ICC because my current research interests are focused on

Gravitational Waves. In particular I especially interested in studying how interference and diffraction due to gravitational lensing (wave-optics phenomena) on different kinds of lenses (stars, compact objects, galaxies, cosmic strings, etc.) may induce observable patterns in the waveform of the detected signal.

ORCID number: [0000-0003-1720-4061](https://orcid.org/0000-0003-1720-4061)

## Atilà Herms Berenguer



I have joined the ICC because I have been working on space mission projects

for a long time. Specifically, in the SOPHI project of ESA's Solar Orbiter mission, I worked on the design and implementation of the Image Stabilization Test System, also supporting the design of the associated firmware. I am currently involved in the LISA project, supporting the Diagnostics and Simulation System.

ORCID number: [0000-0001-9917-9669](https://orcid.org/0000-0001-9917-9669)

## Maria Moreno-Cardoner



Maria Moreno-Cardoner research focuses on the quantum interaction

between light and matter. She is particularly interested in the study of collective effects arising in atomic systems due to light-induced dipole-dipole interactions, such as super- and subradiance phenomena, and how these can be used to enhance the atom-photon coupling at the quantum level, key for the future development of quantum technologies. She has joined the Quantum Technologies group in October 2020 from the Institute of Theoretical Physics at the University of Innsbruck (AG Prof. Ritsch).

ORCID number: [0000-0003-3583-2467](https://orcid.org/0000-0003-3583-2467)

## Arnau Rios Huguet



Arnau Rios joined the ICCUB in September 2020 as a Ramón y Cajal fellow. His postdoctoral career

includes a research contract at the National Superconducting Cyclotron Laboratory at Michigan State University (USA); and a Marie Curie Fellowship, followed by a 5-year STFC Advanced Fellowship, at the University of Surrey (UK). He was a permanent staff member at Surrey (Senior Lecturer) since 2015 and has retained a Visiting Professorship there. Arnau's research interests lie in nuclear theory and in the quantum mechanics of many-body systems, including nuclei and neutron stars. To study these systems, he has exploited a number of techniques, including most recently quantum Machine Learning. At the ICCUB, Arnau is looking forward to establishing new collaborations across fields, connecting ultracold atomic systems to the extreme properties of neutron stars in gravitational wave and astroparticle physics.

ORCID number: [0000-0002-8759-3202](https://orcid.org/0000-0002-8759-3202)

## Héctor Gil-Marín receives the Young Researcher in Theoretical Physics Prize

The prize was awarded to Dr. Gil-Marín as one of the most brilliant researchers of his generation in the field of cosmology and for his outstanding contributions to the analysis and interpretation of galaxy mapping, which allowed advancing in our understanding of the accelerated Universe.

Dr. Gil-Marín is taking part in the mapping project Dark Energy Spectroscopic Instrument (DESI), to measure the effects of dark energy in the expansion of the Universe.



## José Luís Bernal awarded with the SEA Thesis Award 2020

Our former PhD student José Luis Bernal wins the XVI Prize for the Spanish Doctoral Thesis in Astronomy and Astrophysics with his work "Cosmology on the Edge of the  $\Lambda$ -Cold Dark Matter".

Supervised by the cosmologist Licia Verde, José Luis Bernal defended his thesis last September, 13th, and is currently doing a postdoctoral stay at Johns Hopkins University (JHU, Baltimore, United States).



# TECHNOLOGICAL UNIT

---

## Gaia

On December 3rd, 2020, the Early Gaia Data Release 3 (EDR3) was published, with astrometric and photometric data for 1.8 billion stars from our Galaxy. Our team played a key role in its preparation. Besides, we implemented tools for the validation of new data types to be published in DR3, and the first pipelines for DR4 were executed in MareNostrum, including the initial cross-matching and instrumental calibrations.

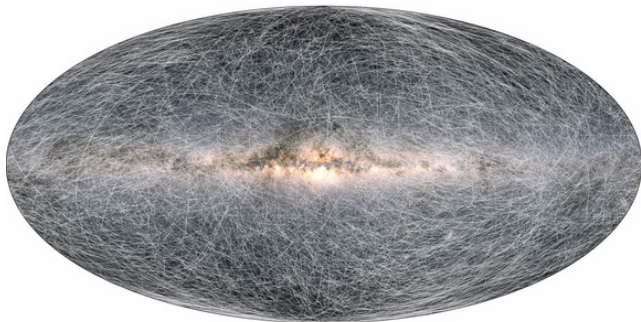

**Fig. 1:** The trails on this image show the displacement of stars on the sky 400 thousand years into the future. Image Credit: ESA/Gaia/DPAC, CC BY-SA 3.0 IGO.

## Ariel

The ICC is participating through the IEEC in the Ariel mission led by RAL. Its main task is the development of the Telescope Control Unit that includes the control of an On-Board Calibration Unit and the Thermal Sensing and Control of the telescope.

## PLATO

In collaboration with other teams at IEEC (mostly from ICE), our team prepared the initial proposal for the ground-based follow-up specification.

## LHCb

The calorimeter Front End Board (FEB) was tested in detail at Orsay with a dedicated crate, acquisition and control servers. Its analog circuit integration was firstly validated at the ICCUB laboratory and, secondly, in close collaboration with the IJCLAB. After these tests, the overall FEB design was reviewed and its production was launched.

In addition to the previous activities, the pre-production boards were installed and checked in their final position in the detector using the full acquisition chain system of the LHCb Experiment.



**Fig. 1:** FEB for the Calorimeter Upgrade in the LHCb experiment. Each one includes 8 ICECAL chips designed and produced by the ICCUB Technological Unit

## CTA

The technological unit designed a new ACTA ASIC version based on AMS CMOS 0.35um technology, in order to implement a "test pulse" functionality to be able to perform electrical tests at the front end level. Additionally, the technological unit managed the production of 50 wafers to equip the 9 MST NectarCAM for the CTA-north observatory in La palma, and 4 LST for the CTA-south observatory.

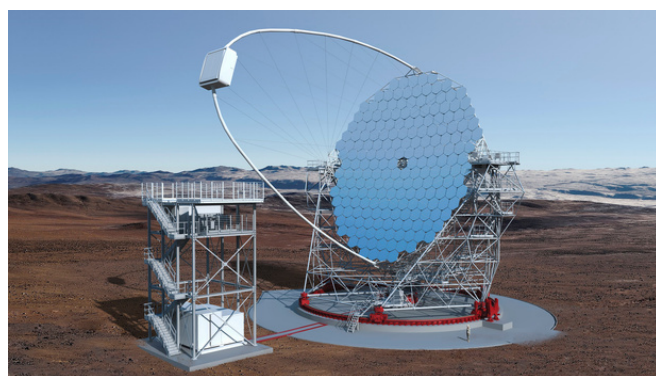

**Fig. 2:** Image Credit: Gabriel Pérez Diaz, IAC

## HERD

The group implemented the 16-channel BETA ASIC developed in a 130 nm technology developed for the SiPM readout of the Scintillating Fiber Tracker (FIT) at the HERD facility. The ASIC is being studied to be also employed in the Plastic Scintillator (PSD) as a trigger also in the HERD. The ASIC is currently under experimental test. This work will be presented at the NSS 2021 conference.



## Virgo

The Technological unit defined the PSD electronics for the SQB1 and SQB2 detectors at the SIN subsystem of the interferometer. We also worked on a denoising algorithm for the coherent wave bursts pipeline, aiming at improving the detectability of unmodelled GW events.

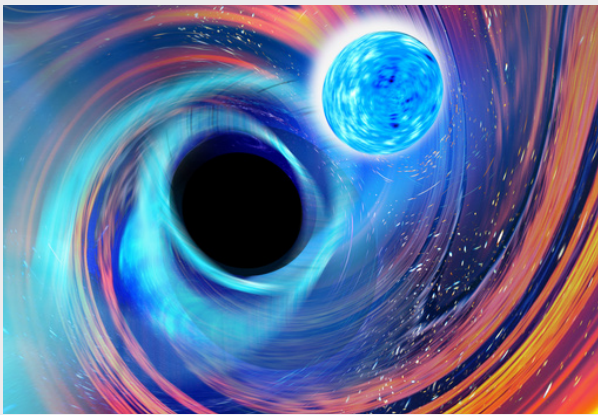

**Fig. 1:** Rainbow Swirl is an artistic image inspired by a Black Hole Neutron Star merger event. Image credit: Carl Knox, OzGrav - Swinburne University

## IAXO

The ICCUB designed the radiopure readout electronics for the Micromegas sensor and launched the production for laboratory tests. Detailed Monte Carlo simulation studies of their effect on the noise were carried out.

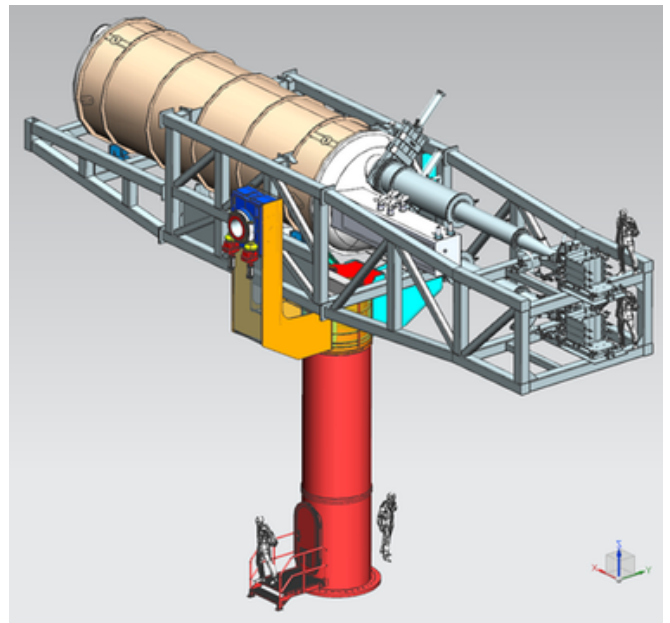

**Fig. 2:** Image Credit: Gabriel Pérez Díaz, IAC

## Solar Orbiter

In February 2020 the Solar Orbiter was launched from the Kennedy Space Center. The launch was successful, and since then, commissioning activities have been on-going, with positive results.



**Fig. 3:** ESA's Solar Orbiter mission will face the Sun from within the orbit of Mercury at its closest approach. Image credit: ESA/ATG medialab

## FASTIC

During the previous years the group implemented the 8-channel FastIC ASIC developed in CMOS 65 nm technology suitable for the readout of positive and negative polarity sensors in High Energy Physics experiments, Cherenkov detectors and Time-of-Flight systems, such as TOF-PET. The ASIC has been tested experimentally during these years obtaining excellent results and improving the time performance of its antecessor, the HRFlexToT ASIC. This work will be presented at the NSS 2021 conference and TWEPP 2021.

## MATRIX16

In 2020 the ASIC was received from the manufacturer. The chip prototype samples were verified and characterized, thus obtaining 8 ps time resolution with very low power consumption (9 mW per channel).

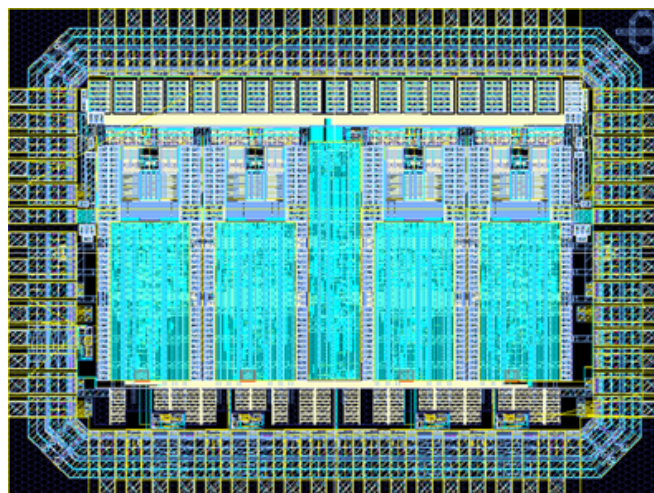
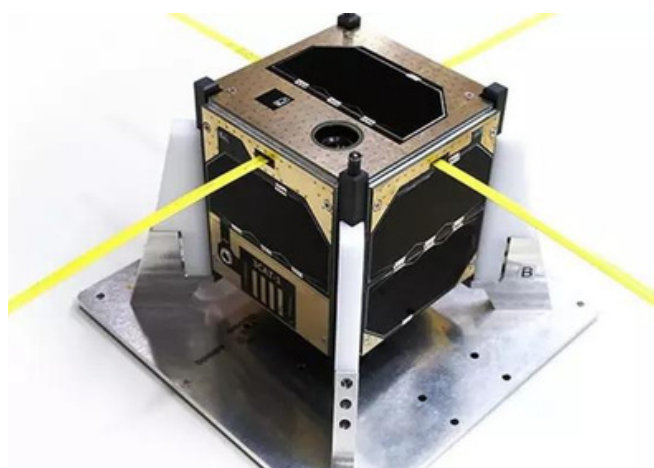

Fig. 2: Design of the MATRIX16

## Nanosatellites

The group of Nanosatellites in the IEEC has participated in the development of the NewSpace strategy for Catalonia, starting point of a future Catalan Space Agency.



# OUTREACH

---

The ICCUB research groups are very active in the dissemination of their activity in schools and public centers, and since its establishment, the Institute has provided economic and human support to the extent possible. Thanks to the María de Maeztu award, the Institute has been able to significantly expand this support. The Institute's main outreach activities are:

- Publication of outreach articles
- Astronomy sessions, courses and public talks
- "Taller de Física de Partículas" organization
- Fabrication and management of itinerant exhibitions.
- Astronomic events follow-up

698  
ACTIVITIES  
IN 2020



# MASTERCLASS ON PARTICLE PHYSICS 2020

The Masterclass on Particle Physics is an activity addressed to high school students in their final year, as part of the international activity Hands on Particle Physics. The workshop has taken place at the UB since 2005 and lasts one day, during which students attend talks about Physics and study real data from LHC. The students also visit the laboratories and attend a presentation about the courses offered at the Faculty of Physics.

In 2020 one out of two sessions was held on the 28th of February because of the COVID-19 pandemic at the Faculty of Physics.



79  
STUDENTS

ATTENDANCE

63

HIGH SCHOOLS

# TRAVELLING EXHIBITIONS

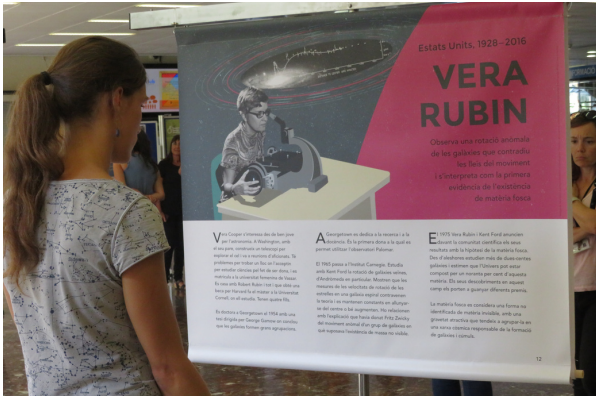

The ICCUB owns eight travelling exhibitions. These exhibitions have different printed versions that are displayed annually in different external centers, like high schools, libraries or community centers. All the exhibitions also have online versions, some of them translated in several languages.



In 2020, **65** centers have requested to display one of these travelling exhibitions disseminating scientific knowledge in their local communities.

## exhibitions

- Dones i Física
- De la Terra a l'Univers
- Amb A d'AstrònomA
- Les distàncies còsmiques
- Mil milions d'ulls per a mil milions d'estrelles
- Viatge cap a l'univers fosc
- Telescopi Assumpció Català
- Investigadores en Física Nuclear



DESTINATIONS



TRAVELLING EXHIBITIONS

# OTHER OUTREACH ACTIVITIES

---

ICCUB members give outreach talks addressed both to students and general public; they also give courses and participate in workshops, science festivals or students fairs. They assist high school students on their final projects, organize astronomical observations, and give coverage to remarkable astronomical ephemeris.



## REMARKABLE OUTREACH ACTIVITIES

### Physics Experiments 2020

From January 27 to February 5, a group of professors and students from the faculty of physics of the UB and the ICC organized a workshop where highschool students could perform different physics experiments such as: observations of the sun, creation of a fog chamber, experimenting with new materials, working with lasers and holograms, etc.



## First teacher's training Day - ADMIRA project

The first training day of the course Activities with Medipix detectors to investigate Radiation in the classroom, (ADMIRA project) took place on January 10, at the Aula Magna of the Faculty of Physics. The workshop was aimed for school teachers and professors, who want to bring research closer to their students and promote new scientific and technical careers. The course had over 50 attendees, and counted with the presence of CERN researcher and ADMIRA creator Rafel Ballabriga, ICCUB researchers Eugeni Graugés and Pol Bordas, and teacher Daniel Parcerisas, from the Institut Sagrada Família.



## World Space Week 2020

World Space Week was declared by the UN General Assembly to celebrate each year the contributions of space science and technology to human development. This year's theme was "Satellites improve life" and in that context, ICCUB researchers Mercè Romero and Eduard Masana delivered the Virtual colloquium on the Milky Way and Gaia.



## Dark Matter Day 2020

Professor Jordi Miralda of the ICCUB offered a virtual conference to celebrate Dark Matter Day 2020. In this talk, he discusses the recent 2019 Nobel Prize which celebrated, among other things, the theory of cold dark matter by James Peebles, which explains how galaxies could be formed based on small changes in the density of the early Universe only thanks to the key role who played dark matter.



## 11F conference "Women in Scientific Research"

To celebrate the International Day of Women and Girls in Science, we organised an activity where the audience was invited to reflect upon the inequalities that women still suffer in academia to this day. The event was divided in two parts, first the conference "Quantifying the biases of scientific success" by Dr. Roberta Sinatra (University of Copenhagen) and finally a debate where Dr. Sinatra was joined by Joaquina Álvarez (CSIC) and Núria Salan (UPC) to discuss several issues related to women in science such as the Glass Ceiling or the Matilda Effect.





# UltraCold UB / QuantumLab workshops 2020

The UltraCold and QuantumLab workshops are part of the Simulations of Quantum Mechanics project, which aims to introduce basic concepts of quantum mechanics and the physics of ultracold gases to the students of baccalaureate and degree. They are based on the development of computer programs created by students under the supervision of professors.

In the workshops, students are able to make simulations with computers of several experiments in which the quantum properties of matter are revealed. In particular, the simulation of the movement of a set of ultra-cold atoms trapped in a potential well (analogy with the movement of a pendulum), the simulation of the movement of a soliton in an atomic gas at temperature 0 K or the simulation of a quantum Newton pendulum.

During 2020, both workshops were seen at the YoMo Festival, at the Science Association "Bojos per la Ciència", the UB Science Fest, and the Barcelona's Science Week. The project is coordinated by researchers Burno Juliá, Muntsa Guilleumas and Artur Polls, and counts with the help of PhD students and collaborators.



# Quarks: the building blocks of matter

Have you ever wondered what the Universe is made of? With the workshop **"Quarks, the building blocks of matter"** you will learn about the particles that make up all matter in our Universe using a three-dimensional puzzle designed at CERN, the European Centre of Nuclear Research. With this activity, we will approach the fundamental laws that determine how these particles come together to form protons and neutrons and how they interact among each other. This workshop is the creation of several members of the Hadronic Physics Group of the University of Barcelona.



## 3D Constellations

In the project Constellations in 3D you will find a virtual tour of the galaxy by Gaia, and how to build the Orion constellation in three dimensions.

### Gaia: The Galaxy in 3D

It is a virtual tour where visitors will be able to see various materials related to the mapping of the sky and the measurement of stellar distances. The highlight of the workshop will be Gaia's virtual reality program that will allow us to virtually travel through our Galaxy.

### 3D Constellations: Orion

We will build the Orion constellation in three dimensions, taking into account both the position and the distance of the stars that form it.

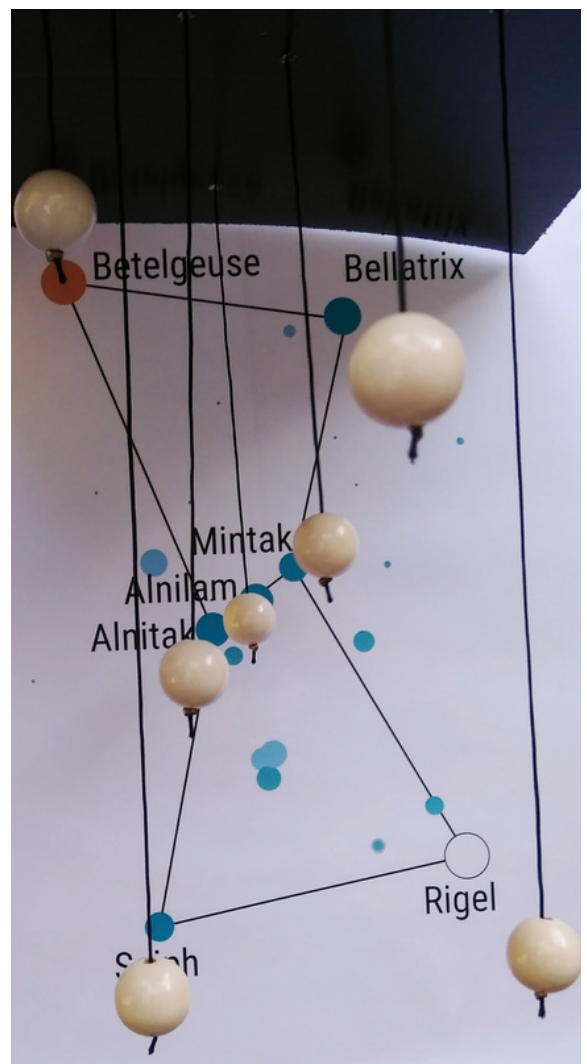

# PUBLICATIONS, PRESS & MEDIA

During 2020 the Institute's members have actively participated in the dissemination of science, through the publication of popular science books and articles in journals and magazines; giving interviews about their groups' scientific publications to press and television; commenting about discoveries or remarkable achievements as experts, and participating in roundtables and debates in radio shows.

The astrophysicist **Xavier Luri Carrascoso** talked about astronomy, physics and Hollywood films in the program *Són 4 dies* of Radio Nacional Española (RNE).

Theoretical physicist **Roberto Emparan de Salazar** explains the details of the latest findings of the VIRGO/LIGO project in *El Pou* of Ràdio Sant Cugat.



## Media appearances

Our researchers gave written statements and comments about scientific articles and discoveries in their appearances in the media.

131

APPEARANCES

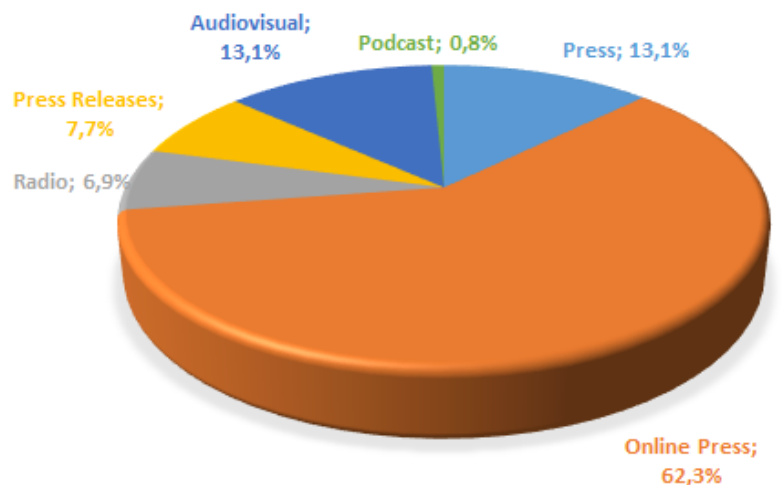

## TELEVISION

Héctor Gil-Marín interviewed about the Sloan Digital Sky Survey (SDSS) in the News (TV3 Telenotícies).



## PRESS

Josep Maria Gómez Cama interviewed by La Vanguardia, regarding the Solar Orbiter Satellite by ESA.

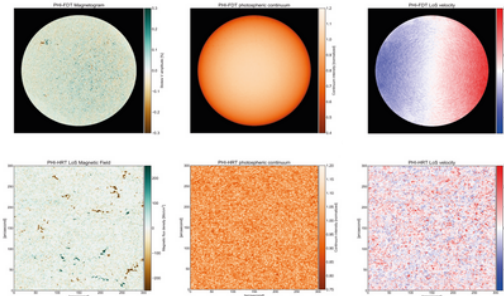

## ONLINE MEDIA

Teresa Antoja interviewed by the magazine Ambientum about the III release of data for the Gaia mission.



## Social Media appearances

Our social media strategy has been to increase the Institute's visibility among the scientific community and to reach a more global audience through the outreach twitter account.



FOLLOWERS  
@ICC\_UB



FOLLOWERS  
@ICCUB\_DIVULGA

